



MAXIGRIP CUPS

These vacuum cups have been created as an alternative to the ordinary cups used in the robot-automotive field. They offer an excellent solution to gripping and handling problems that could arise on vacuum-driven handlers in every industry sector.

They can be both round and oval, flat and bellows-type, and equipped with support. The extremely flexible outside lip, which can be associated with the typical features of the bellows cups, helps them adapt on flat, concave and convex surfaces with no risk of deforming or breaking even the thinnest objects to be handled.

The innovative design of the inside of the cups, which facilitates the drainage of oil and water, ensures a high friction coefficient with the gripping surface and, in particular, a unique grip on oil-covered metal sheets or wet glass or marble sheets. This particular feature guarantees a firm grip and, therefore, accurate placement of the load to be handled.

MAXIGRIP standard vacuum cups are made with our exclusive BENZ compound:

- Hardness 60-75°Sh.
- Working temperature between -40 and +170°C
- Stain-resistant
- Excellent resistance to abrasion, water and to oils containing chlorine.

Their support is vulcanised onto the cup. A wide range of accessories, such as adapters, couplers and articulated joints, allows them to be installed on any vacuum-driven handler.

These cups can also be provided in the special compounds listed on pg. 31, thanks to their universality of use.



ROUND FLAT AND BELLOWS VACUUM CUPS

VACUUM CUPS WITH VULCANISED SUPPORT

Item	Force Kg	Volume cm ³	A Ø	B Ø	Sp	D Ø	d Ø	E	F	G	H	I	SW	Support material	Weight g
VRP 40 A*	3.14	3.7	26	G1/4"	15	40	17	16	14	4.0	31	15	6	aluminium	33.6
VRP 50 A*	4.90	7.4	30	G3/8"	19	50	21	18	14	5.0	33	15	6	aluminium	49.3
VRP 60 A*	7.06	13.9	30	G3/8"	19	60	21	21	14	6.0	36	15	6	aluminium	55.3
VRP 80 A*	12.56	29.6	35	G3/8"	19	80	21	25	14	7.5	40	15	6	aluminium	74.9
VRP 100 A*	19.62	51.6	35	G3/8"	19	100	21	25	14	9.5	40	15	6	aluminium	80.7
VRP 125 A*	30.66	96.5	35	G3/8"	19	125	21	33	14	12.5	48	15	6	aluminium	139.6

* Complete the code indicating the compound: B= BENZ rubber; N= natural para rubber; S = silicone

Note: Can be supplied with NPT threading for minimum quantities of 100 pieces per item.

Ordering example: VRP 80 A NPT B

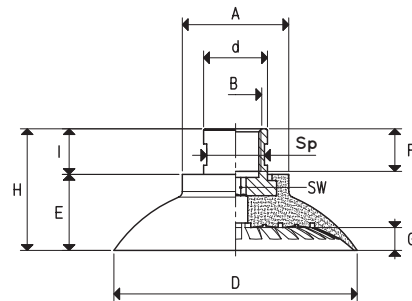

BELLOWS VACUUM CUPS WITH VULCANISED SUPPORT

Item	Force Kg	Volume cm ³	A Ø	B Ø	C Ø	Sp	D Ø	d Ø	E	F	G	H	I	M Ø	Support material	Weight g
VRS 40*	3.14	9.7	43	30	G1/4"	17	40	24	21.0	10	7.0	35.0	14	G1/8"	steel	56.3
VRS 50*	4.90	15.6	53	40	G3/8"	22	50	34	21.0	10	7.0	36.0	15	G1/4"	steel	77.6
VRS 60*	7.06	22.8	63	50	G3/8"	22	60	44	21.0	10	7.0	36.0	15	G1/4"	steel	107.9
VRS 80*	12.56	47.3	83	70	G3/8"	22	80	64	23.0	10	9.0	38.0	15	G1/4"	steel	205.9
VRS 100*	19.62	104.2	103	80	G3/8"	22	100	79	29.0	10	13.0	44.0	15	G1/4"	steel	269.0
VRS 125*	30.66	202.5	128	105	G3/8"	22	125	100	32.5	10	16.5	47.5	15	G1/4"	steel	464.2

* Complete the code indicating the compound: B= BENZ rubber; N= natural para rubber; S = silicone

Note: Height "C" available with NPT threading. Ordering example: VRS 80 NPT B

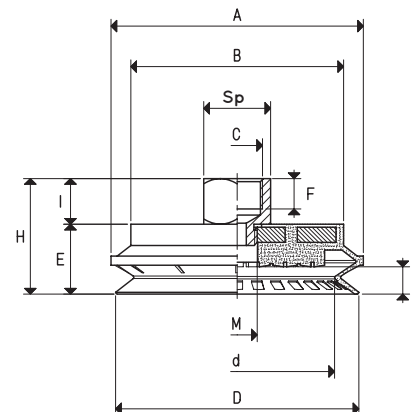

Note: The force of the vacuum cups indicated in the table represents 1/3 of the value of the theoretical force calculated at a level of vacuum of -75 KPa and a factor of safety 3.

Transformation ratio: N (newton) = Kg x 9.81 (force of gravity)

inch = $\frac{\text{mm}}{25.4}$; pounds = $\frac{\text{g}}{453.6} = \frac{\text{Kg}}{0.4536}$

Adapters for GAS - NPT threading available on page 1.130